

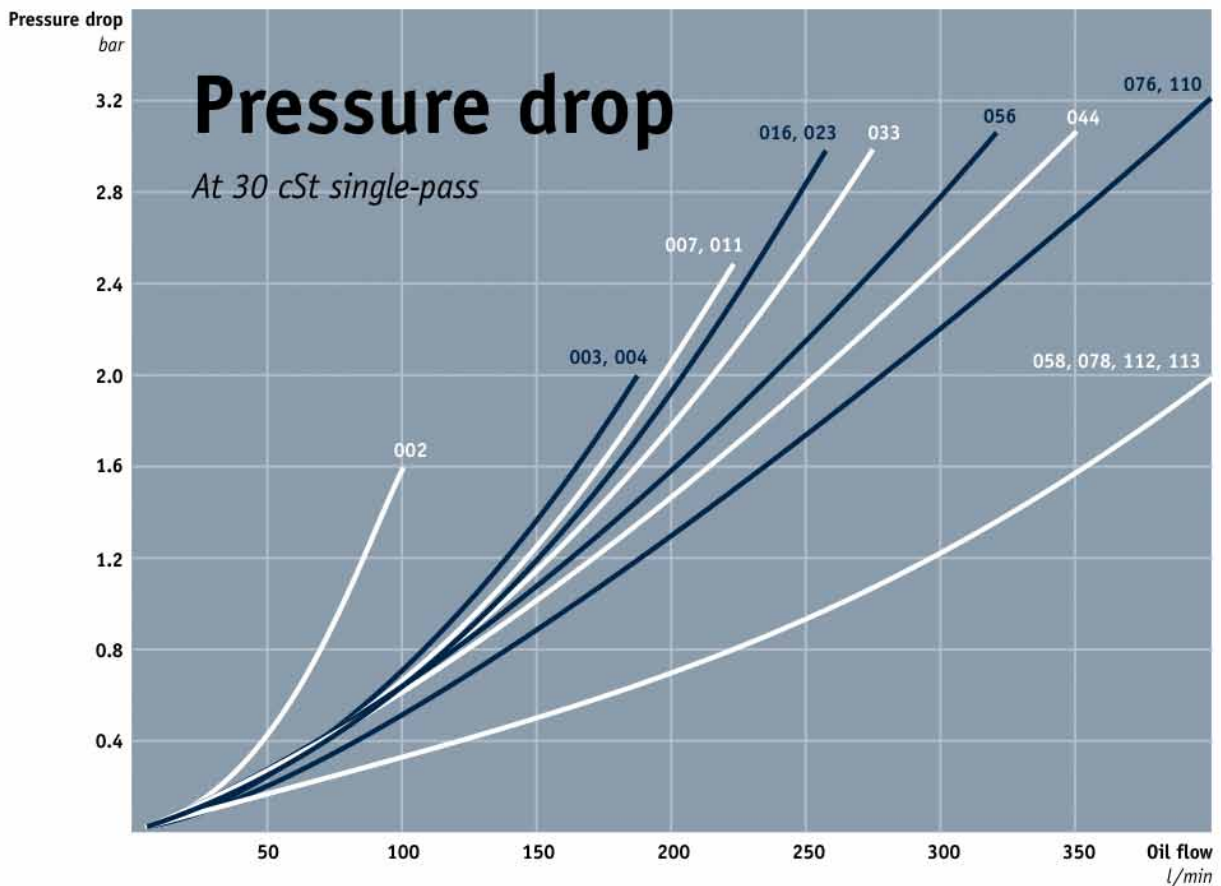

The cooling capacity curves are based on the inlet oil temperature and the ambient air temperature. An oil temperature of 60 °C and an air temperature of 20 °C produce a temperature difference of 40 °C. Multiply by kW/°C for total cooling capacity.

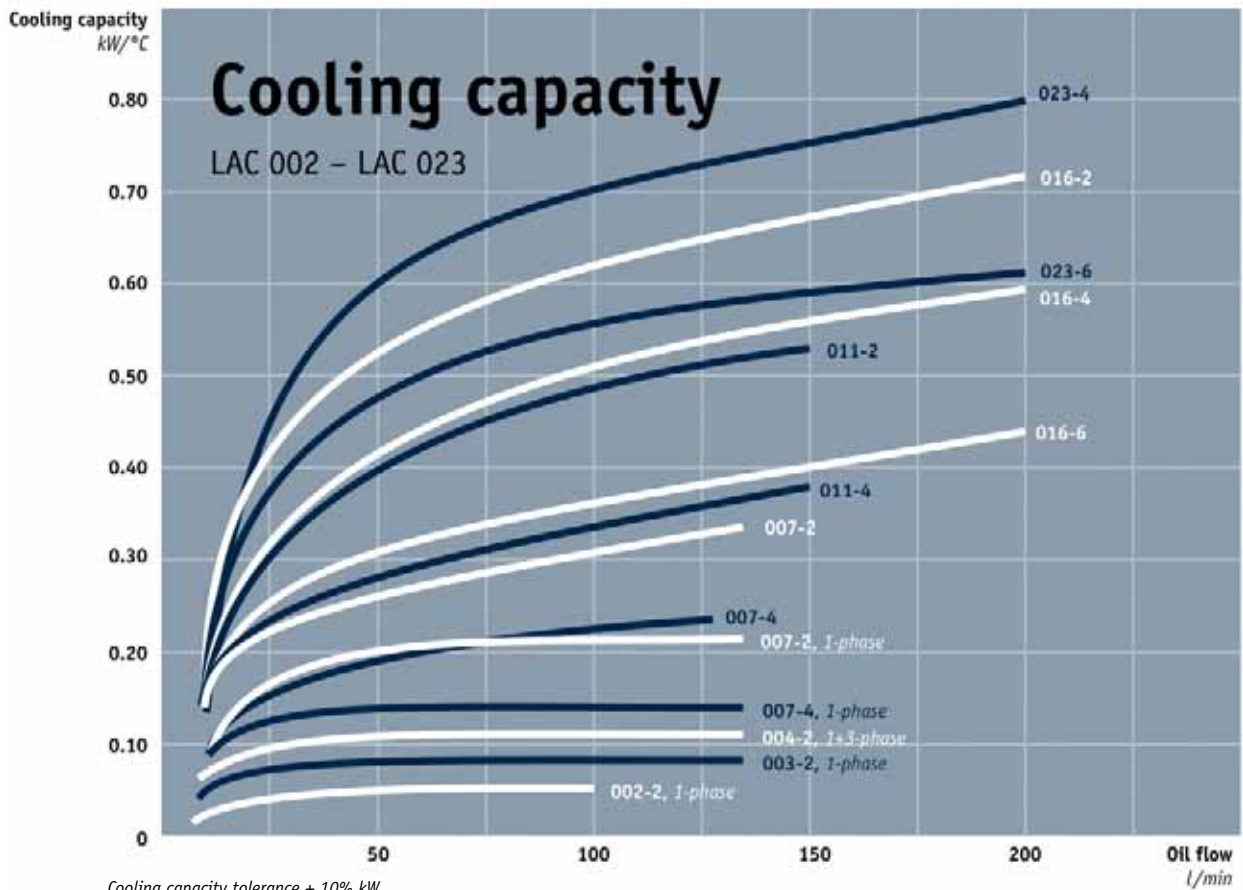

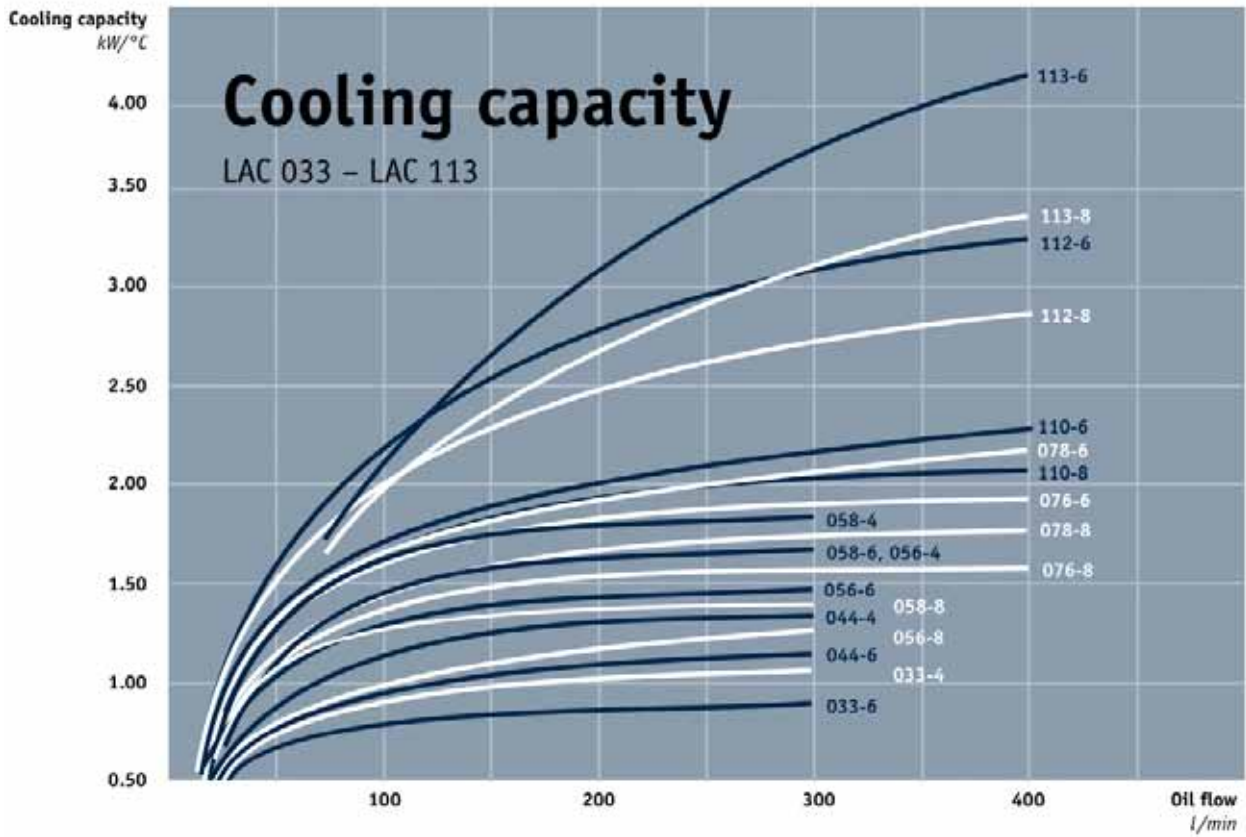

Cooling capacity tolerance  $\pm 10\%$  kW.

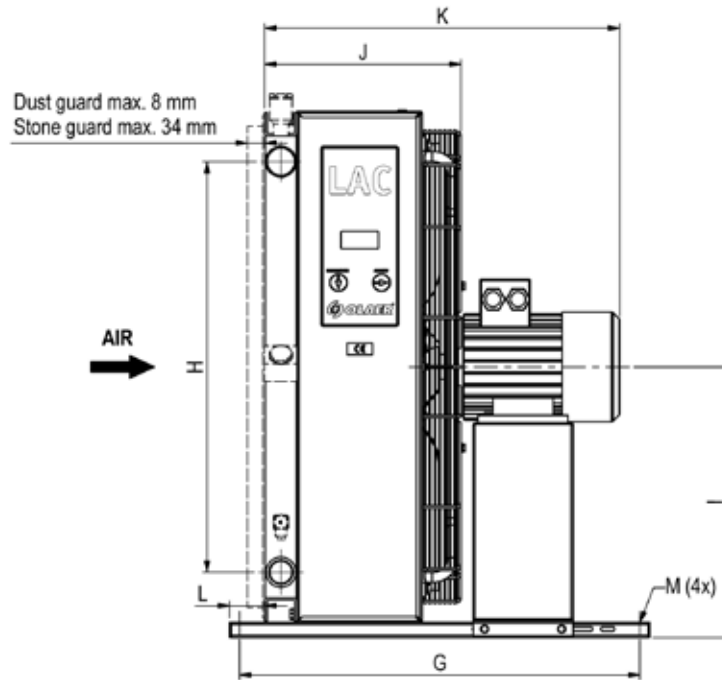

TYPE	Acoustic pressure level $L_p A$ dB(A) 1m*	No. of poles/ Capacity kW	Weight kg (approx)
LAC 002-2-single-phase	50	2-0.05	4
LAC 003-2-single-phase	61	2-0.05	5
LAC 004-2-single-phase	63	2-0.07	6
LAC 002-2-three-phase	63	2-0.07	6
LAC 007-4-single-phase	65	2-0.08	9
LAC 007-2-single-phase	79	2-0.24	10
LAC2 007-4-three-phase	62	4-0.25	15
LAC2 007-2-three-phase	79	2-0.55	16
LAC2 011-4-three-phase	67	4-0.25	20
LAC2 011-2-three-phase	82	2-1.10	25
LAC2 016-6-three-phase	60	6-0.18	23
LAC2 016-4-three-phase	70	4-0.37	24
LAC2 016-2-three-phase	86	2-1.10	27
LAC2 023-6-three-phase	64	6-0.18	35
LAC2 023-4-three-phase	76	4-0.75	36
LAC 033-6-three-phase	74	6-0.55	45
LAC 033-4-three-phase	84	4-2.20	52
LAC 044-6-three-phase	76	6-0.55	63
LAC 044-4-three-phase	85	4-2.20	65
LAC 056-8-three-phase	73	8-0.55	73
LAC 056-6-three-phase	81	6-1.50	75
LAC 056-4-three-phase	84	4-2.20	75
LAC 058-8-three-phase	74	8-0.55	80
LAC 058-6-three-phase	82	6-1.50	82
LAC 058-4-three-phase	85	4-2.20	82
LAC 076-8-three-phase	79	8-1.10	130
LAC 076-6-three-phase	86	6-2.20	140
LAC 078-8-three-phase	80	8-1.10	136
LAC 078-6-three-phase	87	6-2.20	146
LAC 110-8-three-phase	84	8-2.20	160
LAC 110-6-three-phase	90	6-5.50	170
LAC 112-8-three-phase	85	8-2.20	168
LAC 112-6-three-phase	91	6-5.50	178
LAC 113-8-three-phase	80	8-2.20	218
LAC 113-6-three-phase	88	6-5.50	237
LAC 200-8-three-phase	86	8-4.0	365
LAC 200-6-three-phase	92	6-11.0	405

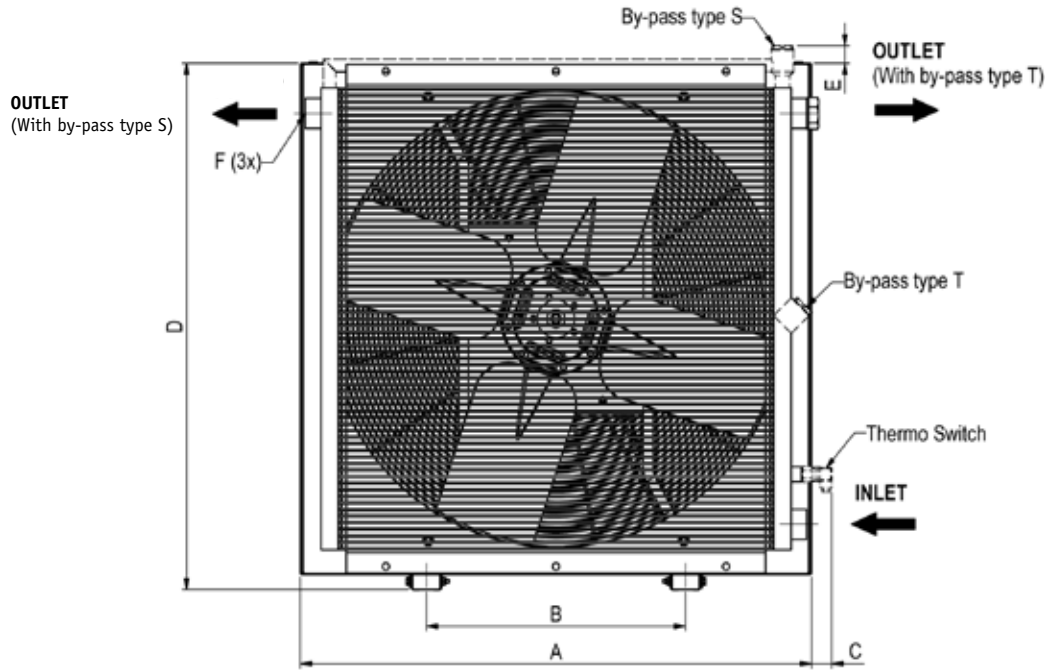

TYPE	A	B	C	D	E	F	G	H	I	J	K	L	M $\varnothing$
LAC 002-2-single-phase	155	74	68	186	-	G $\frac{1}{2}$	186	72	99	92	153	37	9
LAC 003-2-single-phase	210	134	68	223	73	G1	145	90	118	112	225	27	9
LAC 004-2-single-phase	250	134	68	259	66	G1	145	90	131	117	230	27	9
LAC 002-2-three-phase	250	134	68	259	66	G1	145	90	131	117	230	27	9
LAC 007-4-single-phase	340	203	64	343	52	G1	267	160	213	135	252	56	9
LAC 007-2-single-phase	340	203	64	343	52	G1	267	160	213	135	252	56	9
LAC2 007-4-three-phase	365	203	64	395	42	G1	510	160	213	225	429	50	9
LAC2 007-2-three-phase	365	203	64	395	42	G1	510	160	213	225	434	50	9
LAC2 011-4-three-phase	440	203	62	470	41	G1	510	230	250	249	453	50	9
LAC2 011-2-three-phase	440	203	62	470	41	G1	510	230	250	249	475	50	9
LAC2 016-6-three-phase	496	203	66	526	46	G1	510	230	278	272	474	50	9
LAC2 016-4-three-phase	496	203	66	526	46	G1	510	230	278	272	479	50	9
LAC2 016-2-three-phase	496	203	66	526	46	G1	510	230	278	272	496	50	9
LAC2 023-6-three-phase	580	356	63	610	44	G1	510	305	320	287	489	50	9
LAC2 023-4-three-phase	580	356	63	610	44	G1	510	305	320	287	511	50	9
LAC 033-6-three-phase	692	356	53	722	42	G1 $\frac{1}{4}$	510	406	376	318	534	50	9
LAC 033-4-three-phase	692	356	53	722	42	G1 $\frac{1}{4}$	510	406	376	318	618	50	9
LAC 044-6-three-phase	692	356	53	866	59	G1 $\frac{1}{4}$	510	584	448	343	559	50	9
LAC 044-4-three-phase	692	356	53	866	59	G1 $\frac{1}{4}$	510	584	448	343	643	50	9
LAC 056-8-three-phase	868	508	49	898	43	G1 $\frac{1}{4}$	510	584	448	343	643	50	9
LAC 056-6-three-phase	868	508	49	898	43	G1 $\frac{1}{4}$	510	584	464	368	668	50	9
LAC 056-4-three-phase	868	508	49	898	43	G1 $\frac{1}{4}$	510	584	464	368	668	50	9
LAC 058-8-three-phase	868	508	49	898	43	G2	510	584	464	388	652	30	9
LAC 058-6-three-phase	868	508	49	898	43	G2	510	584	464	388	682	30	9
LAC 058-4-three-phase	868	508	49	898	43	G2	510	584	464	388	688	30	9
LAC 076-8-three-phase	1022	518	41	1052	45	G1 $\frac{1}{2}$	800	821	541	393	693	70	14
LAC 076-6-three-phase	1022	518	41	1052	45	G1 $\frac{1}{2}$	800	821	541	393	710	70	14
LAC 078-8-three-phase	1022	518	41	1052	45	G2	800	821	541	413	713	50	14
LAC 078-6-three-phase	1022	518	41	1052	45	G2	800	821	541	413	730	50	14
LAC 110-8-three-phase	1185	600	54	1215	45	G2	800	985	623	418	785	70	14
LAC 110-6-three-phase	1185	600	54	1215	45	G2	800	985	623	418	785	70	14
LAC 112-8-three-phase	1185	600	54	1215	45	G2	800	985	623	438	805	50	14
LAC 112-6-three-phase	1185	600	54	1215	45	G2	800	985	623	438	805	50	14
LAC 113-8-three-phase	1200	600	82	1215	45	G2	860	985	623	465	833	82	14
LAC 113-6-three-phase	1200	600	82	1215	45	G2	860	985	623	465	871	82	14
LAC 200-8-three-phase	Please contact Olaer for more information												
LAC 200-6-three-phase	Please contact Olaer for more information												

# Key for LAC and LAC2 air oil coolers

All positions must be filled in when ordering

## EXAMPLE:

LAC2 - 016 - 6 - A - 50 - T20 - D - 0

1 2 3 4 5 6 7 8

### 1. AIR OIL COOLER

WITH AC MOTOR = LAC / LAC2

### 2. COOLER SIZE

002, 003, 004, 007, 011, 016, 023, 033, 044,  
056, 058, 076, 078, 110, 112, 113 and 200.

### 3. NUMBER OF POLES, MOTOR

2 - pole	= 2
4 - pole	= 4
6 - pole	= 6
8 - pole	= 8

### 4. VOLTAGE AND FREQUENCY

No motor	= 0
Three-phase 220-240/380-420 V 50 Hz*	= A
Three-phase 440-480 V 60 Hz*	= B
Single-phase 230 V 50/60 Hz**	= C
Three-phase 220-240/380-420 V 50 Hz 440/480 V 60 Hz***	= D
Three-phase 500 V 50 Hz	= E
Three-phase 400/690 V 50 Hz 440-480 V 60 Hz	= F
Three-phase 525 V 50 Hz	= G
Motor for special voltage (stated in plain language)	= X

\* = for LAC 033 to LAC 113, \*\* = contact Olaer for frequency 60 Hz

\*\*\* = for LAC 007 to LAC 023

### 5. THERMO CONTACT

No thermo contact	= 00
40 °C	= 40
50 °C	= 50
60 °C	= 60
70 °C	= 70
80 °C	= 80
90 °C	= 90

### 6. COOLER MATRIX

Standard	= 000
Two-pass	= T00

#### Built-in, pressure-controlled bypass, single-pass

2 bar	= S20
5 bar	= S50
8 bar	= S80

#### Built-in, pressure-controlled bypass, two-pass\*

2 bar	= T20
5 bar	= T50
8 bar	= T80

#### Built-in temperature and pressure-controlled bypass, single-pass

50 °C, 2.2 bar	= S25
60 °C, 2.2 bar	= S26
70 °C, 2.2 bar	= S27
90 °C, 2.2 bar	= S29

#### Built-in temperature and pressure-controlled bypass, two-pass\*

50 °C, 2.2 bar	= T25
60 °C, 2.2 bar	= T26
70 °C, 2.2 bar	= T27
90 °C, 2.2 bar	= T29

\* = not for LAC 002 - LAC 004

### 7. MATRIX GUARD

No guard	= 0
Stone guard	= S
Dust guard	= D
Dust and stone guard	= P

### 8. STANDARD/SPECIAL

Standard	= 0
Special	= Z

## Technical specification

### FLUID COMBINATIONS

Mineral oil	HL/HLP in accordance with DIN 51524
Oil/water emulsion	HFA, HFB in accordance with CETOP RP 77H
Water glycol	HFC in accordance with CETOP RP 77H
Phosphate ester	HFD-R in accordance with CETOP RP 77H

### MATERIAL

Cooler matrix	Aluminum
Fan blades/hub	Glass fibre reinforced polypropylene/ Aluminum
Fan housing	Steel
Fan guard	Steel
Other parts	Steel
Surface treatment	Electrostatically powder-coated

### TECHNICAL DATA, COOLER MATRIX

Maximum static operating pressure	21 bar
Dynamic operating pressure	14 bar*
Heat transfer limit	± 6 %
Maximum oil inlet temperature	120 °C

\* Tested in accordance with ISO/DIS 10771-1

### TECHNICAL DATA FOR 3-PHASE MOTOR

3-phase asynchronous motors in accordance with IEC 34-1 and IEC 72 in accordance with DIN 57530/VDE 0530	
Insulation class	F
Rise of temperature	B
Protection class	IP 55

### TECHNICAL DATA FOR 1-PHASE MOTOR

Insulation class	B
Rise of temperature	B
Protection class	IP 44

### TECHNICAL DATA FOR 3-PHASE MOTOR LAC 004

Rated voltage	230/400V 50/60 Hz
Insulation class	B
Rise of temperature	B
Protection class	IP 44

### COOLING CAPACITY CURVES

The cooling capacity curves in this technical data sheet are based on tests in accordance with EN 1048 and have been produced using oil type ISO VG 46 at 60 °C.

### CONTACT OLAER FOR ADVICE ON

Oil temperatures > 120 °C
Oil viscosity > 100 cSt
Aggressive environments
Ambient air rich in particles
High-altitude locations

The information in this brochure is subject to change without prior notice.