



LHC

With hydraulic motor - optimized for mobile and industrial use
Installation and servicing manual

SE GB DE FR ES



1

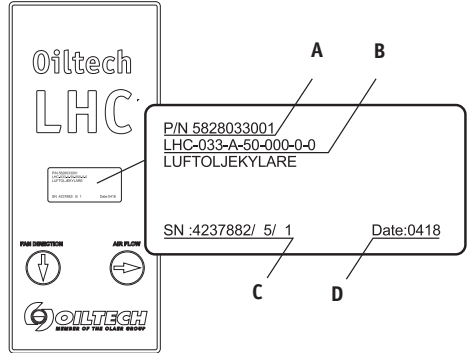

2

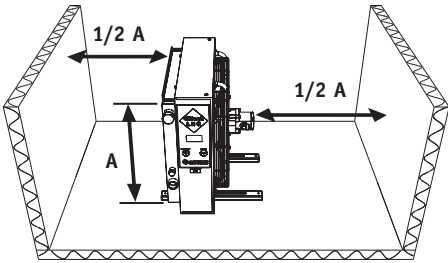

3

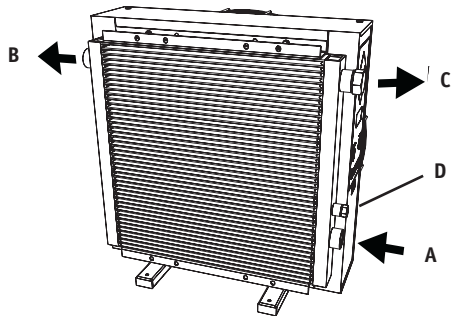

4

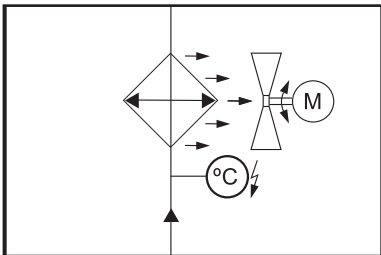

5

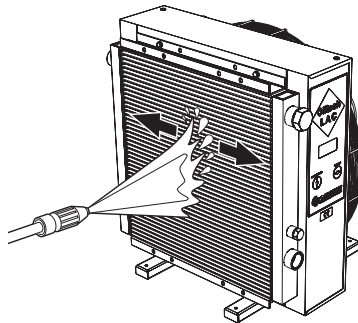

6

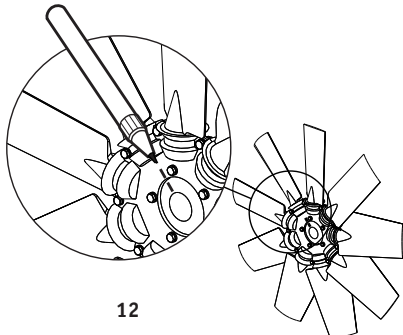
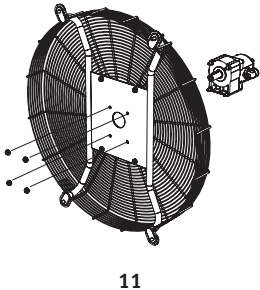
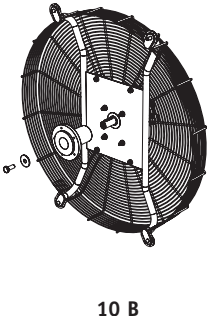
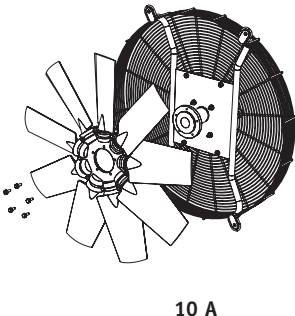
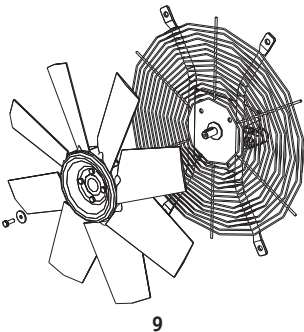
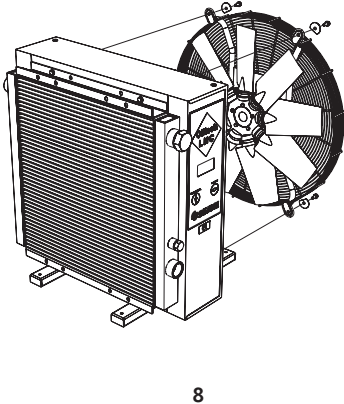
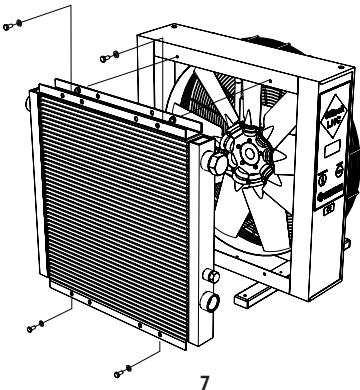

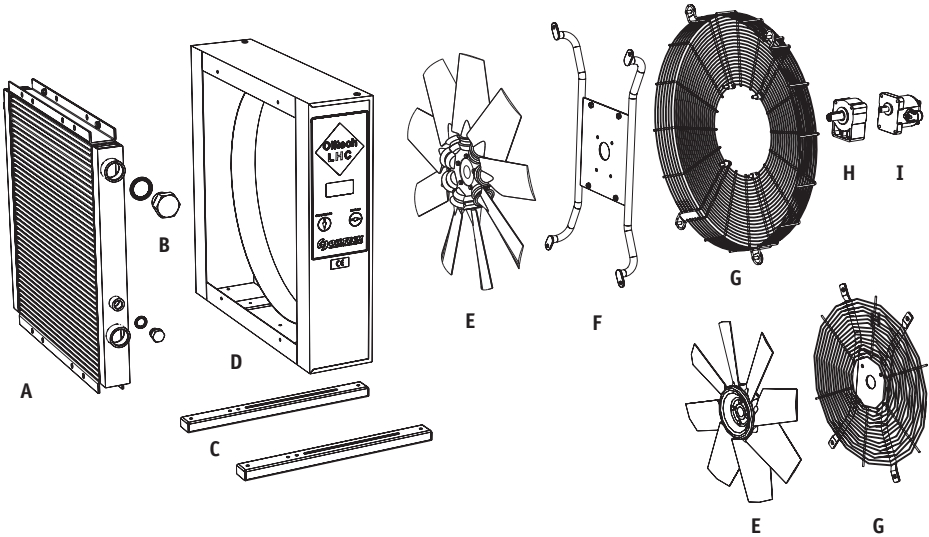

Komponentförteckning

- A** Kylelement
- B** Pluggar och gummistålbrickor
- C** Fötter
- D** Fläkthus
- E** Fläktenhet*
- F** Motorfäste
- G** Fläktgaller
- H** Stödlager**
- I** Hydraulmotor

* *Utförandet, fast eller löst nav, varierar med kylarmodell*

** *Finns på kylarmodell från och med storlek 033.*

Komponentenverzeichnis

- A** Kühlelement
- B** Stopfen und Gummistahlscheiben
- C** Füße
- D** Lüftergehäuse
- E** Lüftereinheit*
- F** Motorhalterung
- G** Schutzgitter
- H** Vorsatzlager**
- I** Hydraulikmotor

* *Die Ausführung mit starrer oder loser Nabe hängt vom Kühlermodell ab.*

** *Ab Kühlergröße 033 verfügbar.*

Lista de componentes

- A** Radiador
- B** Tapón ciego con junta metalbuna
- C** Patas
- D** Caja del ventilador
- E** Ventilador completo*
- F** Soporte del motor
- G** Rejilla de protección
- H** Cojinete de empuje**
- I** Motor hidráulico

* *El asiento del ventilador, fijo o desmontable, dependerá del tipo de intercambiador.*

** *A partir del tamaño 033*

Part list

- A** Cooler matrix
- B** Plugs and rubber steel washers
- C** Support
- D** Fan housing
- E** Fan unit*
- F** Motor attachment
- G** Fan guard
- H** Collar bearing**
- I** Hydraulic motor

* *The design, fixed or detachable hub, is depending on type of cooler.*

** *Available as from size 033.*

Liste des composants

- A** Radiateur
- B** Bouchons et joints à lèvres
- C** Pieds
- D** Caisson ventilateur
- E** Hélice complète*
- F** Support moteur
- G** Grille ventilateur
- H** Contre paliers**
- I** Moteur hydraulique

* *La conception, moyeu fixe ou non fixe, varie suivant le modèle d'échangeur.*

** *Disponible dès la taille 033.*

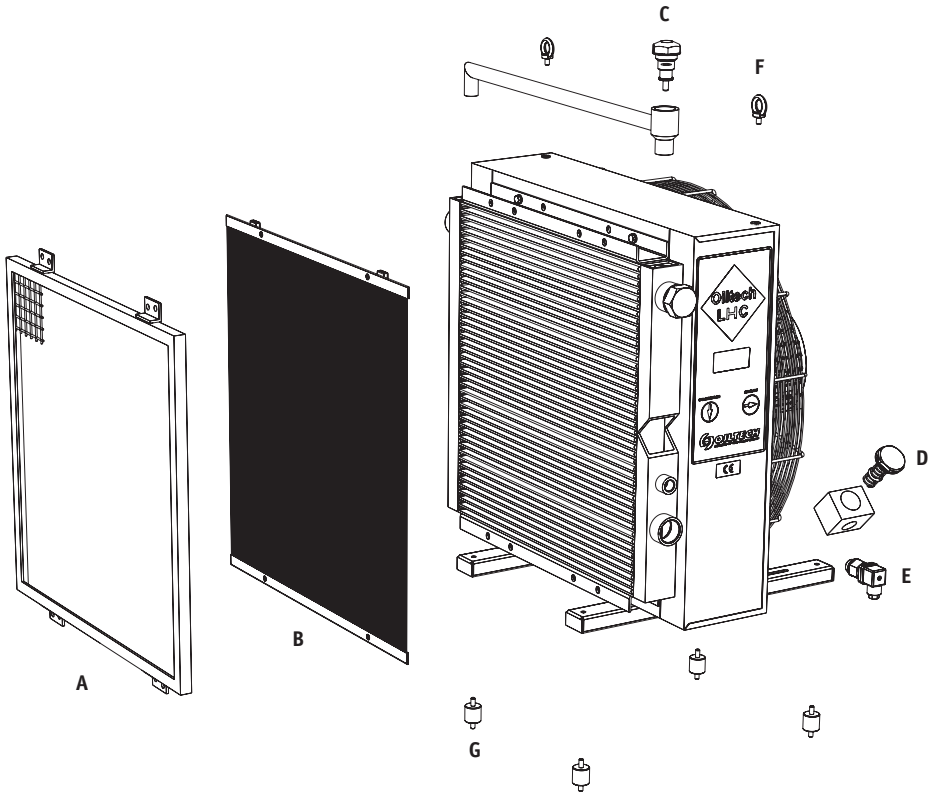

Tillval

- A Stenskydd
 - B Dammskydd
 - C S-Bypass ventil, enpassage*
 - D T-Bypassventil, tvåpassage*
 - E Termokontakt
- * Kan fås som tryckstyrd eller temperatur- och tryckstyrd bypass.

Tillbehör

- F Lyftöglor
- G Vibrationsdämpare

Options

- A Stone guard
 - B Dust guard
 - C S-Bypass valve, single-pass*
 - D T-Bypass valve, two pass*
 - E Thermo contact
- * Pressure controlled or temperature and pressure controlled by-pass.

Options

- F Lifting eye
- G Vibration dampener

Sonderzubehör

- A Steinschutz
 - B Staubschutz
 - C S-Bypassventil, Einzeldurchlauf*
 - D T-Bypassventil, Doppeldurchlauf*
 - E Termokontakt
- * Mit Drucksteuerung oder Temperatur- und Drucksteuerung lieferbar.

Zubehör

- F Hebeösen
- G Vibrationsdämpfer

Équipements en option

- A Grille de protection
 - B Filtre antipoussière
 - C S-Valve by-pass, 1-passe*
 - D T-Valve by-pass, 2-passes*
 - E Thermocontact
- * Disponible comme bypass commandée par pression ou par température et pression.

Accessoires

- F Anneaux de levage
- G Patins antivibratoires

Equipamientos opcionales

- A Rejilla protectora para piedras
 - B Filtro antipolvo
 - C S-Válvula by-pass, un paso*
 - D T-Válvula bypass, dos pasos*
 - E Termostato
- * Disponible como by-pass controlado por presión o por temperatura y presión.

Accesorios

- F Cáncamos de elevación
- G Silent blocs

Introduction

This manual is meant to serve as a reference guide for installation, maintenance and operation of the Oiltech LHC-series of air oil cooler.

Keep the manual at hand. A lost manual should be replaced as soon as possible.

For optimum performance and in order to prevent incorrect use, please read this manual carefully and observe all safety precautions prior to putting the air oil cooler into service.

Installation and maintenance work should be carried out by qualified personnel only.

Oiltech/Olaer reserve the right to make technical alterations without notice.

Use The Oiltech LHC-series of air oil coolers is designed to cool hydraulic fluids in systems for industrial and mobile applications.

Warranty and claims In the event of breakdown, consult your local Olaer office. Olaer/Oiltech shall not be held responsible for any consequences due to modification made by the customer.

Safety instructions

The installation contractor as well as the user should be aware of, understand and observe all safety precautions in this manual, including any information mentioned on labels fixed to the product.

Definition of Safety Warning Levels...

...concerning personal safety

All precautions concerning personal safety are classified as per below, depending on how severe the consequences of an incident could be.

 **Danger** This alerts you to an action or procedure that, if performed improperly, **will produce** bodily harm or death.

 **Caution** This alerts you to an action or procedure that, if performed improperly, **is likely to** produce bodily harm or death.

 **Precaution** This alerts you to an action or procedure that, if performed improperly, **is likely to** cause an accident with bodily harm.

...concerning other safety issues

Notifications concerning other safety issues (property, process or environment) and maintenance work are classified as follows:

Important This alerts you to an action or procedure that, if performed improperly, **is likely to** result in damage to the product, process or environment.

...concerning additional information

Additional information is marked as follows:

Note! This alerts you to important information related to the text in a paragraph.

Overall instructions

Lifting

 **Caution** Risk of bodily injury. To prevent bodily harm when lifting the unit, ensure correct lifting technique. Make sure that all lifting devices are free from damage and approved for the weight of the air oil cooler.

Installation, operation, handling and maintenance

 **Caution** Risk of bodily injury. Disconnect the motor power supply prior to maintenance.

 **Caution** Risk of bodily injury. Before disconnecting the hydraulic hoses and connections, make sure the system is depressurized.

 **Caution** Risk of severe burns. This indicates danger from high temperature surfaces. The air oil cooler could become extremely hot during operation. Always make sure the cooler is cool before touching.

 **Precaution** Risk of bodily injury. If the air oil cooler is fitted with a thermo contact, the fan will start automatically when the preset temperature has been reached. Be careful when standing close to rotating units.

 **Precaution** This indicates a toxic hazard. To prevent bodily injury, damage to property or environment, used fluid should be collected and taken to a special depot.

Important Risk of damage to the hydraulic system. Contamination, water and air will increase wear on hydraulic components, which could lead to breakdown. The most important practice to observe when working on the hydraulic system is cleanliness.

Important Static electricity. Fans generate static electricity. Do not put sensitive devices (electronics etc.) in the immediate vicinity of the air oil cooler. Antistatic fans are available on request.

Note! Use ear defenders when standing close to an operating air oil cooler for long periods of time.

Warning label

The warning label shown below is fitted to the oil cooler prior to delivery. Always replace a damaged or missing label.

- **Caution!** High temperature surface! Use ear defenders! Rotating fan! (P/N 500029 - 70x30 mm or P/N 5000291 - 120x50 mm). See Figure 1.

Description

Principally the LHC air oil cooler consists of a cooler matrix, a hydraulic motor, a fan, a fan housing and a fan guard.

The cooler matrix and the hydraulic motor are connected to the hydraulic system with hydraulic hoses.

Different hydraulic motor types are used in the LHC series of air oil coolers. Normal ambient temperature for the hydraulic motor is $-20\text{ }^{\circ}\text{C}$ – $60\text{ }^{\circ}\text{C}$.

For general technical information, see Technical data.

Larger coolers are fitted with a collar bearing for prolonged hydraulic motor life.

If the air oil cooler is fitted with a thermo contact for temperature sensing, the fan will start automatically when the preset temperature has been reached.

The acoustic pressure could reach 64-92 LpA dB(A) at 1 m distance under normal operating conditions depending on air oil cooler size. Inappropriate location of the air oil cooler could generate increased acoustic pressure level and reduced cooling capacity to allow for good air flow, i.e. optimal cooling capacity.

Identification plate

The cooler identification plate is fitted on the fan housing. See Figure 2. On the label you will find information about

- A** - Part number
- B** - Designation
- C** - Serial number
- D** - Date of delivery (year and week, e.g. 0818, i.e. year 08 and week 18).

Replace a damaged or missing label as soon as possible.

Installation

Lifting

 **Caution** Risk of bodily injury. To prevent bodily harm when lifting the unit, ensure correct lifting technique. Make sure that all lifting devices are free from damage and approved for the weight of the air oil cooler.

Air oil coolers as from size 033 are prepared for installation of lifting eyes. Lifting eyes are available from Oiltech/Olaer on request.

Mounting

 **Precaution** Risk of bodily harm. Make sure that the air oil cooler is securely fixed.

The air oil cooler can be mounted in any position. However, upright is recommended (standing on its feet). A free space corresponding to a minimum of half the height

of the matrix (A) should be available in front of and behind the air oil cooler to allow for good air flow, i.e. optimal cooling capacity as well as low acoustic pressure level. See Figure 3.

Inappropriate location of the air oil cooler or operation under extreme conditions could generate increased acoustic pressure level and reduce cooling capacity.

Important Assembly and hydraulic motor installation should be made in a clean environment.

Connection of cooler matrix

Connect the cooler matrix using flexible hydraulic hoses both to and from the cooler matrix. Connections and hoses should be sized according to the system pressure, flow, temperature and type of system fluid.

Connect the cooler matrix as illustrated below. See Figure 4.

- A** - Inlet.
- B** - Outlet for single pass
- C** - Outlet for two pass
- D** - Thermo contact connection.

Dimensions on connections are cooler matrix size dependent.

Connection chart, see Figure 5.

Important The cooler matrix is designed for maximum dynamic working pressure 14 bar. When the cooler is installed in a return line, there should be no pressure spikes. If this is not possible, an offline cooling system should be used.

Hydraulic motor connection

Important Risk of damage to the hydraulic system. Contamination, water and air will increase wear on hydraulic components, which could lead to breakdown. The most important practice to observe when working on the hydraulic system is cleanliness.

Use flexible hydraulic hoses both to and from the hydraulic motor. Connections and hoses should be sized according to system pressure, flow, temperature and type of system fluid. Prevent throttling and do not use flexible hydraulic hoses with a narrow bending radius.

Connection size depends on hydraulic motor size.

Adjust the oil flow to the hydraulic motor. The maximum rpm of the motor and fan must not be exceeded as this can cause a breakdown.

Be careful, incorrect connection will cause incorrect direction of rotation of the motor and fan see arrow for direction of rotation.

The LHC air oil cooler is fitted with an externally drained hydraulic motor as standard. Connect the hydraulic motor drain hose to the tank. Maximum pressure in drain port is 5 bar.

Electrical connection

If the cooler is fitted with a thermo contact, use a relay if the current load exceeds the maximum load for the thermo contact.

Handling

Prior to initial start-up

 **Precaution** Make sure the air oil cooler is securely fixed and correctly connected.

Be sure to use the correct fluid as well as a high-quality filter element to achieve a high level of cleanliness. Make sure the hydraulic hoses and the tank are clean.

We recommend that you proceed as follows prior to start-up:

- 1 Run the air oil cooler with the system fluid.
- 2 Filter the fluid before passing through the cooler.

See *Technical data* for fluid compatibility, recommended cleanliness level.

Prior to start up

 **Precaution** Do not start the air oil cooler if there is a risk of damage to person, property or environment.

Check:

- that all cooler parts are free from damage,
- that the air oil cooler is correctly connected
- that the fan rotates freely (use hand force),
- that all hydraulic connections are tight,
- that the inside of the fan housing is free from objects that could be thrown around and cause bodily injury or damage to property.

At start-up

Check:

- that the direction of rotation of the fan and the air flow is as indicated by the arrows on the label on the fan housing,
- that the air oil cooler is free from abnormal noise and vibrations,
- the air oil cooler is free from leaks.

Do not overload the motor due to cold start or due to high viscosity oil.

During operation

 **Caution** Risk of severe burns. The air oil cooler could become extremely hot during operation. Make sure that the air oil cooler is cool before touching.

Maximum permitted fluid temperature in the cooler matrix is 120° C. See *Technical data* for recommended fluid temperature in the hydraulic motor.

The cooler matrix is designed for maximum allowed dynamic working pressure 14 bar.

Do not operate the hydraulic motor at a low rpm and a high pressure for an extended time.

Note! Use ear defenders when standing in the immediate vicinity of an operating air oil cooler for long periods of time.

Preventive maintenance

Preventive maintenance work must be carried out at regular intervals.

Important Risk of damage to the hydraulic system. Contamination, water and air will increase wear on components, which could lead to breakdown. The most important practice to observe when working on the system is cleanliness.

Make sure:

- that there is no abnormal noise or vibrations,
- that the air oil cooler is securely fixed,
- that the cooler matrix is clean as debris will reduce the cooling capacity,
- that the fluid cleanliness is as recommended, replace if required,
- that the air oil cooler is free from damage, replace damaged components,
- that the air oil cooler is free from leaks, take adequate measures,
- that warning labels are in good condition, replace any damaged/missing label immediately.

Cleaning

 **Danger** Risk of bodily injury. Prior to cleaning, disconnect all motor power supplies.

 **Caution** Risk of severe burns. The air oil cooler could become extremely hot during operation. Make sure the air oil cooler is cool before touching.

Air oil cooler When cleaning the exterior of the cooler, for instance using water, disconnect all power supplies.

Cooler matrix The air fins of the matrix can be cleaned by blowing through with compressed air. If necessary a high-pressure washing system and degreasing agent can be used.

When using a high-pressure washing system point the jet parallel to the air fins. See *Figure 6*.

Fan housing Remove the cooler matrix when cleaning the inside of the fan housing. To clean the inside of the fan housing, use compressed air. Blow with compressed air from the hydraulic motor side through the fan guard.

Maintenance

Olaer/Oiltech shall not be held responsible for any consequences due to repair and/or modification made by the customer.

Dismounting the cooler matrix



Caution Risk of severe burns. The air oil cooler could become extremely hot during operation. Make sure the air oil cooler is cool before touching.



Caution Risk of bodily injury. Disconnect the motor power supply prior to maintenance.

- 1 Turn off the system.
- 2 Disconnect the hydraulic motor power supply.
- 3 Make sure that the system is depressurized.
- 4 Turn off the fluid supply.
- 5 Disconnect the flexible hydraulic hoses from the cooler matrix.
- 6 Unscrew the screws with washers fixing the cooler matrix to the fan housing. *See Figure 7.*
- 7 Remove the cooler matrix.

Mounting of the cooler matrix

- 1 Locate the cooler matrix.
- 2 Fit the cooler matrix to the fan housing. *See Figure 7.*
- 3 Connect the flexible hydraulic hoses to the cooler matrix. *See Figure 4.*
- 4 Connect the hydraulic motor power supply.
- 5 Proceed to *Prior to start-up* and *At start-up*

Removing the hydraulic motor and the fan



Caution Risk of severe burns. The air oil cooler could become extremely hot during operation. Make sure the air oil cooler is cool before touching.



Caution Risk of bodily injury. Prior to maintenance, disconnect the hydraulic motor power supply.

Important Risk of damage to the hydraulic system. Contamination, water and air will increase wear on hydraulic components, which could lead to breakdown. The most important practice to observe when working on the hydraulic system is cleanliness.

Note! Some fan hubs are fixed, *see Figure 9*, and some are detachable, *see Figure 10 A and Figure 10 B*. The fan is balanced together with the hub as from size LHC-033.

- 1 Turn off the system.
- 2 Disconnect the hydraulic motor power supply.
- 3 Secure the hydraulic motor.
- 4 Unscrew the screws with washer fixing the motor attachment to the fan housing. *See Figure 8.*
- 5 Unscrew the screw with washer fixing the fan to the motor shaft. *See Figure 9.* Pull with care the fan and

hub from the motor shaft. Use a puller if required.

- 6 Unscrew the screws fixing the motor to the motor attachment. *See Figure 11.*
- 7 Remove the motor.

If further dismantling of the fan is required, label all details to ensure correct mounting, first of all with regard to balance and direction of rotation. *See Figure 12.*

Mounting of the hydraulic motor and fan

Note! There are models with fixed hub (*see Figure 9*) and models with detachable hub (*see Figure 10 A and Figure 10 B*). The fan is balanced together with the hub as from size LHC-033.

- 1 Secure the hydraulic motor to the motor attachment. *See Figure 11.*
- 2 Fit the hub in the groove against the key on the motor. Grease the hub with ethanol and secure the fan/hub to the motor shaft. If required, knock carefully with e.g. a rubber mallet. Use Loctite® on the screw and secure the fan/hub on the motor shaft with screws. *See Figure 9.*
- 3 Make sure that the fan is fitted to the motor shaft without too much play.
- 4 Place the motor attachment with fan, fan guard and motor in the fan housing.
- 5 Adjust the fan guard and motor and secure the motor attachment in the fan housing with screws. *See Figure 8.*
- 6 Make sure that the fan is centered and rotates freely (using hand force). If required, adjust the location of the fan guard and motor.
- 7 Check the screws for tightness.
- 8 Connect the hydraulic motor power supply.
- 9 Proceed to *Prior to start-up* and *At start-up*.

Technical data

Cooler matrix

Maximum static working pressure	21 bar
Maximum dynamic working pressure	14 bar*
Heat transfer allowance	± 6%
Maximum fluid temperature in the cooler matrix	120 °C
Maximum cooling capacity	160 kW

* Tested according to ISO/DIS 10771-1

Fluid compatibility

Mineral oil according to DIN 51524	HL/HLP
Oil/water emulsion according to CETOP RP 77H	HFA, HFB
Water glycol according to CETOP RP 77H	HFC
Phosphatester according to CETOP RP 77H	HFD-R

Hydraulic motor

Maximum working pressure (motor with depl. 25.2 = 160 bar)	210 bar
Recommended fluid type	Mineral based hydraulic oil according to DIN 51524 part 2HLP
Recommended oil viscosity	20 - 50 cSt. Min. 10 cSt
Max. operating viscosity	100 cSt
Max. viscosity at cold start	1000 cSt
Recommended fluid temperature	30 – 60 °C. Max. 80 °C
Recommended cleaning level 18/13 or higher according to ISO 4406	

Material

Cooler matrix	Aluminium
Fan housing	Steel
Fan blades/hub	Glass fibre reinforced polypropylene/ aluminium
Fan guard	Steel
Other parts	Steel
Hydraulic motor	See information from the manufacturer
Surface treatment	Electrostatic powder coated

Oiltech LHC air oil coolers could have different material and surface treatments.

EC Declaration Of Conformity

Manufacturer **Oiltech AB**

Product **LHC Air Oil Cooler**

Oiltech AB declares under sole responsibility that the product above to which this declaration relates is in conformity with the Machinery Directive 98/37/EC.

The product complies with the requirements of:

- Safety of machinery – Basic concepts, general principles for design, EN ISO 12100-1 and EN ISO 12100-2.
- Safety of machinery – Safety requirements for fluid power systems and their components – Hydraulics, EN 982.
- Safety of machinery – Safety distance to prevent danger zones being reached by the upper limbs, EN 294.

The above is valid for a complete product delivered by Oiltech and a complete product is CE-marked by Oiltech.

If the product is not delivered complete by Oiltech the product is also not CE-marked by Oiltech and must not be put into service until the product has been declared in conformity with the requirements of the relevant directives and standards.

Certificate of incorporation

If the product is to be incorporated in a machinery the product must not be put into service until the machinery into which it has been incorporated has been declared in conformity with the provisions of the relevant directive and standards.

Lidingö in August, 2008

OILTECH AB

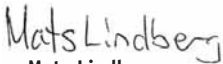

Mats Lindberg

Technical Manager



The Olaer Group develops, manufactures and markets products and systems in five business areas.

Global perspective

and local entrepreneurial flair

The Olaer Group is a global player specialising in innovative, efficient system solutions for temperature optimisation and energy storage. The Group develops, manufactures and markets products and systems for a number of different sectors, e.g. the aircraft, engineering, steel and mining industries, as well as for sectors such as oil and gas, contracting and transport, farming and forestry, renewable energy, etc.

All over the world, our products operate in the most diverse environments and applications. One constantly repeated demand in the market is for optimal energy storage and temperature optimisation.

We work at a local level with a whole world as our workplace – local entrepreneurial flair and a global perspective go hand in hand. Our local presence, long experience and a wealth of knowledge combine with our cutting-edge expertise to give you the best possible conditions for making a professional choice.

OLAER AB | Postbox 10012 | SE-181 10 Lidingö | Sweden | www.oiltech.se
| info@oiltech.se | Phone: +46 (0)8-636 07 00 | Fax: +46 (0)8-767 97 56

AUSTRALIA Olaer FCH. Tel: +61 2 9981 6888. **AUSTRIA** Olaer Austria GmbH. Tel: +43 7229 80306. **BELGIUM** S.A. Olaer Benelux. Tel: +32 2 466 15 15. **CZECH REPUBLIC** Olaer CZ s.r.o. Tel: +42 5 47125 601-8. **DENMARK** Oiltech DK. Tel: +45 86 69 20 38. **FINLAND** Oiltech Hydraulics OY. Tel: +358 9 413 755 00. **FRANCE** Olaer Industries S.A. Tel: +33 1 41 19 17 00. **GERMANY** Olaer Industries GmbH. Tel: +49 6842 9204-0. **HOLLAND** Olaer Nederland B.V. Tel: +31 76 5412453. **INDIA** FCH India. Tel: +91 802 6533587. **ITALY** Olaer Italiana S.p.A. Tel: +39 011 991 85 11. **KOREA** Hyundai Olaer Hydraulic Co. Tel: +82 31 499 0897. **NORWAY** Oiltech AS. Tel: +47 64 91 11 80. **POLAND** Oiltech Polska. Tel: +48 22 6738162. **SOUTH AFRICA** FCH c/o Rolton Products CC. Tel: +27 11 474 3095. **SPAIN** Olaer-Oiltech Iberica SAU. Tel: +34 933 368 900. **SWEDEN** Oiltech AB. Tel: +46 8 636 07 00. **SWITZERLAND** Olaer (Schweiz) AG. Tel: +41 26 492 70 00. **UK** FCH Ltd. Tel: +44 1244 535515. **USA** Oil Air Hydraulics Inc. Tel: +1 713 937 89 00.