

# AVTA

*Thermostatically operated cooling water valves*

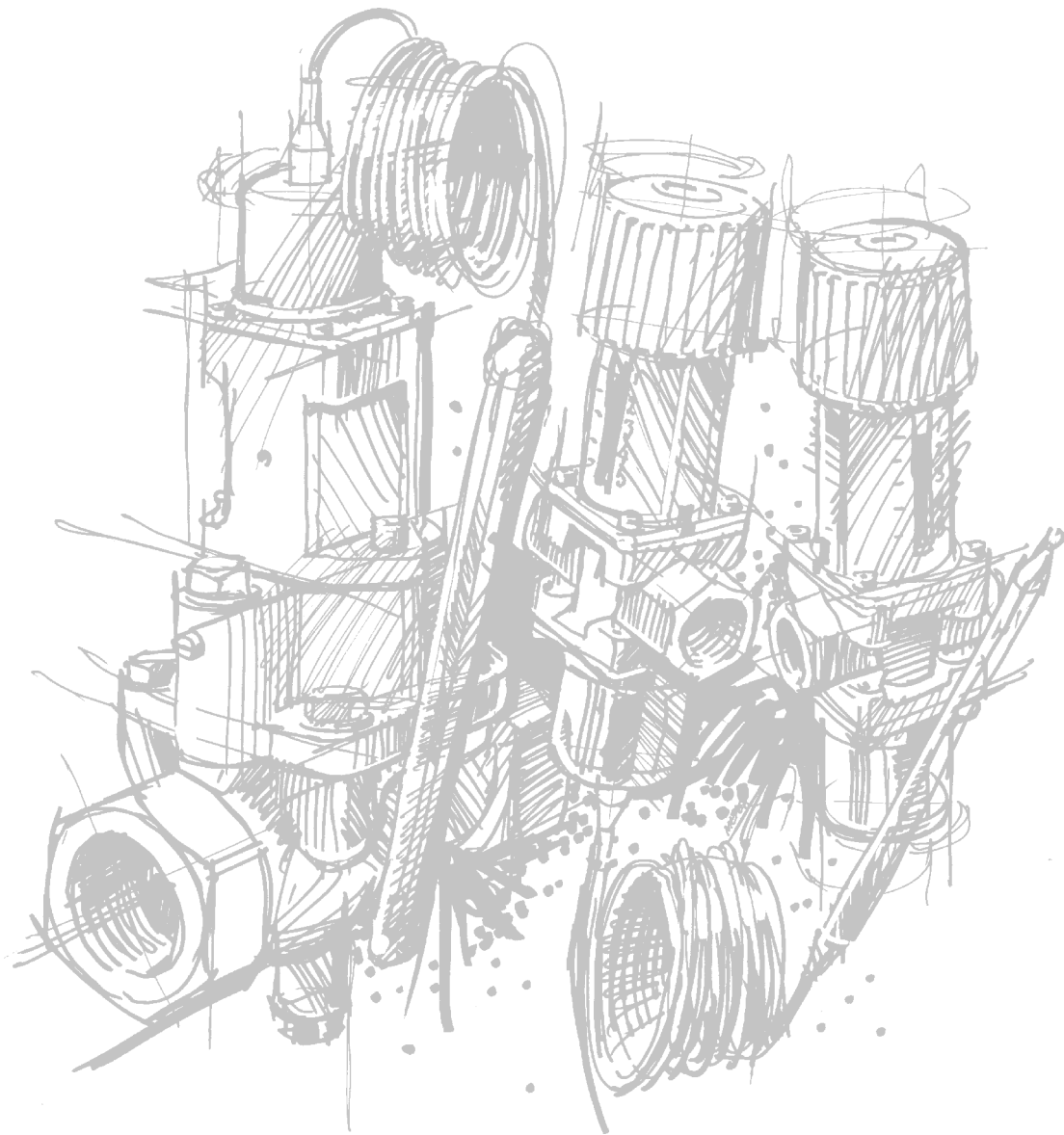

**OILTECH**

MEMBER OF THE OLAER GROUP

# General data on thermostatically operated cooling water valves

## Type AVTA

### Introduction

Thermostatically operated valves are used for the infinite, proportional regulation of flow quantity, depending on the setting and the sensor temperature.

The Oiltech range of thermostatic valves includes a series of industrial products for both refrigeration and heating regulation. The valves are self-acting, i.e. they operate without the supply of auxiliary energy such as electricity or compressed air.

Because the valves constantly match flow quantity to demand, they are especially suitable for temperature regulation.

The required temperature is maintained constant with no overconsumption of:  
 - cooling water in cooling systems,  
 - hot water or steam in heating systems.  
 Thus operating economy is always reasonable.

For further information on thermostatically operated valves for heating regulation, please contact Oiltech.

### Technical data

#### General

Thermostatic valves consist of three main elements:

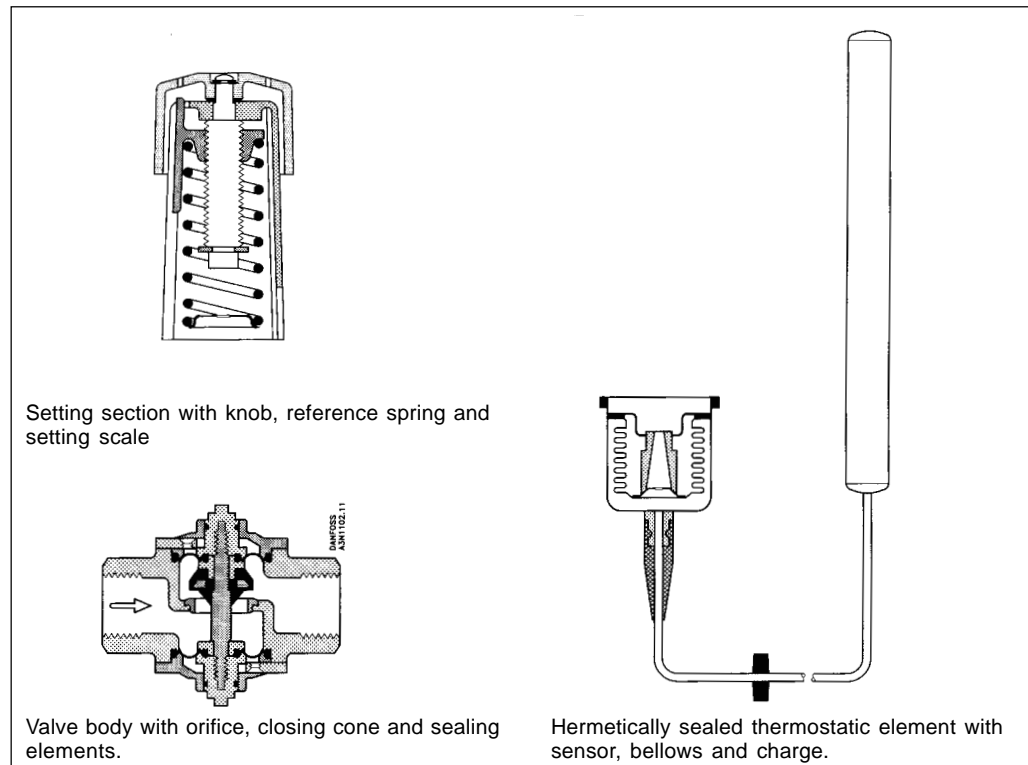

#### Function

When the three elements are built together, the valve is installed and the sensor is located at the point where the temperature is to be regulated, the function sequence is as follows:

1. A temperature-dependent pressure - charge vapour pressure - builds up in the sensor.
2. This pressure is transferred to the valve via the capillary tube and bellows and acts as an opening or closing force.
3. The knob on the setting section and the spring exert a force that acts counter to the bellows.

4. When balance is created between the two opposing forces, the valve spindle remains in its position.

5. If the sensor temperature - or the setting - is changed, the point of balance becomes displaced and the valve spindle moves until balance is re-established, or the valve is fully open or closed.

6. On sensor temperature change, the flow quantity change is approximately proportional.

The illustrations show an AVTA cooling water valve, but the function principle applies to all types of thermostatic valves.

# Thermostatically operated cooling water valves

## Type AVTA for neutral media

### Application



Self-acting AVTA cooling water valves are widely used for temperature regulation in many different machines and installations where cooling is a requirement. AVTA always opens to admit flow on rising sensor temperature. The valve can be installed either in the cooling water flow line or return line.

#### Typical applications:

- Injection moulding machines
- Compressors
- Vacuum pumps
- Dry cleaning machines
- Distillation plant
- Printing machines
- Hydraulic systems
- Rollers/mills

### Specifications and product overview

- Opens on rising sensor temperature
- Media temperature  $-25 \rightarrow +130^{\circ}\text{C}$
- Differential pressure  $0 \rightarrow 10$  bar
- Max. working pressure 16 bar
- Max. test pressure 25 bar
- Max. pressure on sensor 25 bar
- The valves are pressure-relieved, i.e. the degree of opening is not affected by differential pressure  $\Delta p$  (pressure drop).

- The regulation range is defined for the point at which the valve begins to open.

AVTA valves are available with three different types of charge (see pages 4 and 5):

- A: Adsorption charge
- B: Mass charge
- C: Universal charge

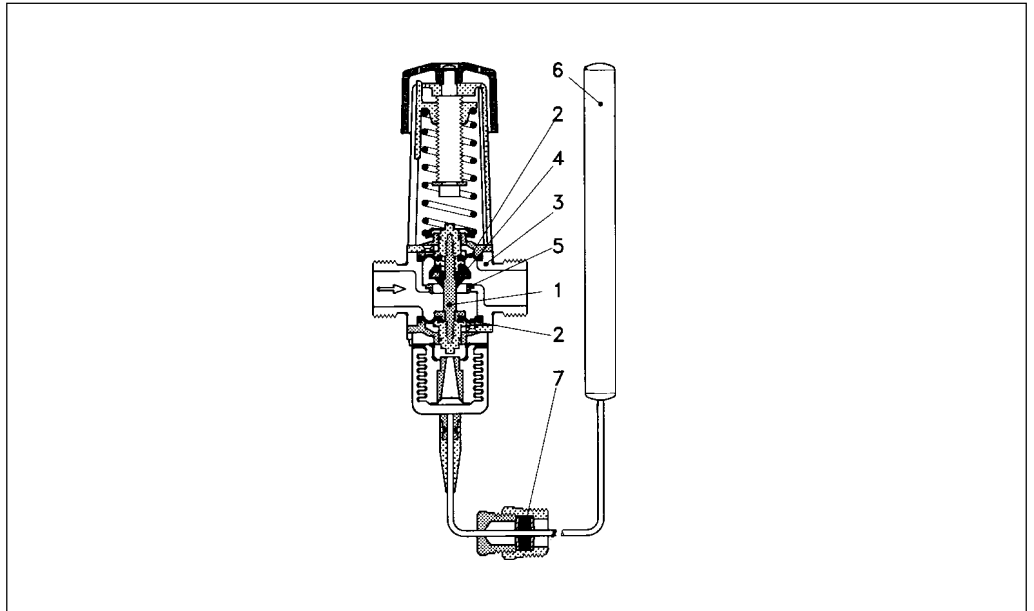

#### Materials - parts in contact with the medium, AVTA

No.	Description	Material	
1	Spindle	Brass	W.no. 2.0401
2	Diaphragms	Rubber - ethylene - propylene (EPDM)	
3	Valve body and other metal parts	Forged brass	W.no. 2.0402
4	Valve cone	Nitrile rubber (NBR)	
5	Valve seat	Stainless steel	W.no. 1.4305 / AISI 303
6	Sensor	Copper	W.no. 2.0090
7	Capillary tube gland	Nitrile rubber (NBR) Brass	W.no. 2.0321 / 2.0401

# Thermostatically operated cooling water valves

## Type AVTA for neutral media

### AVTA with adsorption charge

The charge consists of active carbon and CO<sub>2</sub> which is adsorbed on falling sensor temperature and thereby produce pressure changes in the element.

#### Special characteristics

- Wide regulating range

- Can be installed in any position as far as orientation and - temperature are concerned
- Withstands up to +130°C sensor temperature
- Small sensor dimensions - → 9,5 ↔ 160 mm
- Max. pressure on sensor 25 bar

Connection	Regulating range [°C]	k <sub>v</sub> value (m <sup>3</sup> /h at Δp = 1 bar)	Capillary tube length [m]	Type
G 3/8	10 → 80	1.4	2.3	AVTA 10
G 1/2		1.9		AVTA 15
G 3/4		3.4		AVTA 20
G 1		5.5		AVTA 25

<sup>1)</sup> Code no. covers complete valve incl. capillary tube gland.

Immersion sensors, see "Accessories", page 13.

### AVTA with universal charge

The charge is liquid/gas where the liquid surface (regulating point) is always inside the sensor. Which charge medium is used depends on the temperature range.

#### Special characteristics

- Sensor dimensions → 18 ↔ 210 mm
- Sensor can be installed colder or warmer than the valve
- Sensors must be orientated as shown in the sketch
- Max. pressure on sensor 25 bar

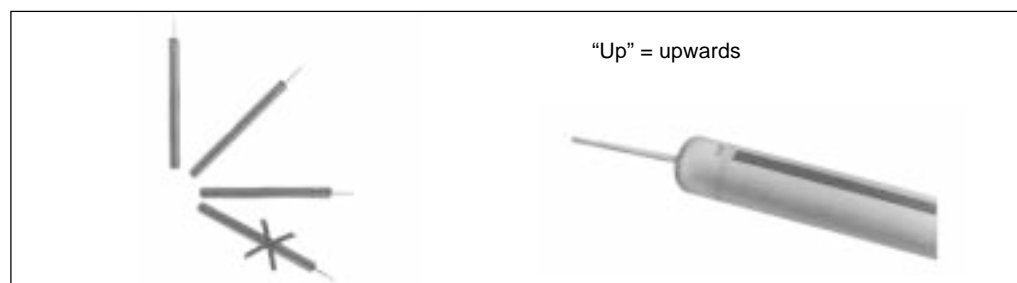

Regulation range 0 → +30°C, max. sensor temperature +57°C

Connection	k <sub>v</sub> value (m <sup>3</sup> /h at Δp = 1 bar)	Capillary tube length	Type
G 3/8	1.4	2 m	AVTA 10
G 1/2	1.9		AVTA 15
G 3/4	3.4		AVTA 20
G 1	5.5		AVTA 25

<sup>1)</sup> Code no. covers complete valve incl. capillary tube gland.

Regulation range 25 → +65°C, max. sensor temperature +90°C

Connection	k <sub>v</sub> value (m <sup>3</sup> /h at Δp = 1 bar)	Capillary tube length	Type
G 3/8	1.4	2 m	AVTA 10
G 1/2	1.9	2 m (armoured)	AVTA 15
		2 m	
G 3/4	3.4	2 m	AVTA 20
		5 m	
		2 m (armoured)	
G 1	5.5	2 m	AVTA 25
		2 m (armoured)	
		5 m	

<sup>1)</sup> Code no. covers complete valve incl. capillary tube gland.

Immersion sensors, see "Accessories", page 8.

# Thermostatically operated cooling water valves

## Type AVTA for neutral media

### AVTA with universal charge

Regulation range +50 → +90°C  
Max. sensor temperature +125°C

Connection	k <sub>v</sub> value (m <sup>3</sup> /h at Δp = 1 bar)	Capillary tube length [m]	Type
G 3/8	1.4	2	AVTA 10
G 1/2	1.9		AVTA 15
G 3/4	3.4		AVTA 20
G 1	5.5	3	AVTA 25

<sup>1)</sup> Code no. covers complete valve incl. capillary tube gland.

<sup>2)</sup> A Ø 2 mm bypass is drilled in the valve body

### AVTA with mass charge

The charge is liquid/gas. Because of the volumetric conditions the liquid surface (regulation point) can be either in the sensor or the bellows, depending on the temperature conditions.

#### Special characteristics

- Small sensor dimensions (Ø 9.5 X190 mm)
- Short time constant
- Sensor must always be installed warmer than the valve
- Max. pressure on sensor 25 bar

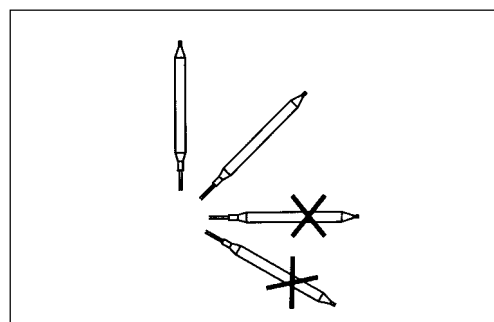

Regulation range 0 → +30°C  
Max. sensor temperature +57°C

Connection	k <sub>v</sub> value (m <sup>3</sup> /h at Δp = 1 bar)	Capillary tube length [m]	Type
G 1/2	1.9	2	AVTA 15
G 3/4	3.4		AVTA 20

<sup>1)</sup> Code no. covers complete valve incl. capillary tube gland.

Regulation range +25 → +65°C  
Max. sensor temperature +90°C

Connection	k <sub>v</sub> value (m <sup>3</sup> /h at Δp = 1 bar)	Capillary tube length [m]	Type
G 1/2	1.9	2	AVTA 15
		2 (armoured)	
		5	
G 3/4	3.4	2	AVTA 20
G 1	5.5		AVTA 25

<sup>1)</sup> Code no. covers complete valve incl. capillary tube gland.



# Installation of thermostatically operated cooling water valves

## Type AVTA

### Installation

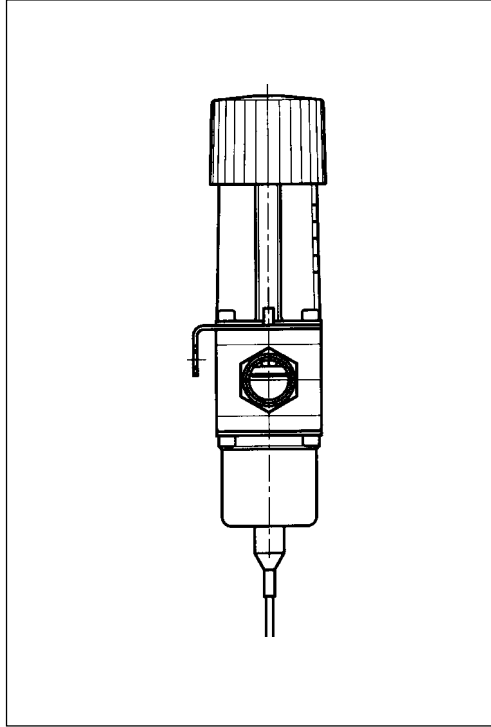

The valves can be installed in any position. An arrow on the valve body indicates the direction of flow.

AVTA valves are also marked so that the letters RA can be read straightforwardly when the valve is held as shown.

The installation of an FV filter ahead of the valve is recommended.

#### Capillary tube

Install the capillary tube without sharp bends (no "kinks"). Relieve the capillary tube at the ends. Relief is important where vibration might occur.

#### Note

Where AVTA is used, the sensor must be able to react to variations in cooling water temperature on system start. Therefore a bypass line with a shut-off valve might be necessary to ensure flow at the sensor during start-up.

If a mounting bracket is used - see "Accessories", page 8 - it must always be between valve body and setting section (see illustration).

### Sensor installation

If an immersion sensor is installed, the use of heat-conductive compound is recommended. This will reduce reaction time. See "Accessories", page 13.

AVTA with small sensor ( $\rightarrow 9.5 \leftrightarrow 190$  mm) must always be installed in the flow line, where the regulated liquid is coldest ("sensor warmer").

#### Adsorption charge

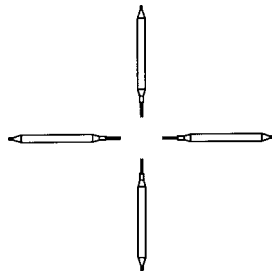

Sensor  $\varnothing 9,5 \times 160$  mm  
(Sensor warmer or colder)

#### Mass charge

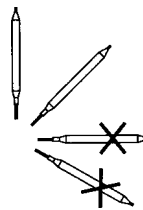

Sensor  $\varnothing 9,5 \times 190$  mm  
(Sensor warmer)

#### Universal charge

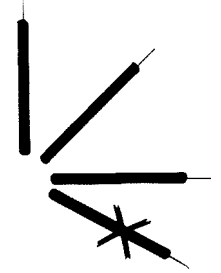

Sensor  $\varnothing 18 \times 210$  mm  
(Sensor warmer or colder)

"Up" = upwards



# Spare parts and accessories for thermostatically operated cooling water valves Type AVTA

## Spare parts and accessories

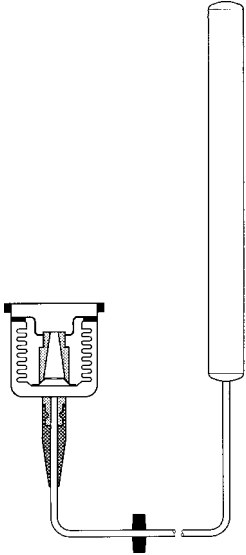

## Service elements for AVTA

	Temperature range [°C]	Capillary tube length [m]
Adsorption charge - sensor $\varnothing 9.5 \times 160$ mm	10 → 80	2.3
Universal charge - sensor $\varnothing 18 \times 210$ mm	0 → 30	2
		5
	25 → 65	2
		5
		2 (armoured)
	3	
50 → 90	2	
	3	
Mass charge - sensor $\varnothing 9.5 \times 190$ mm	0 → 30	2
	25 → 65	2
		2

## Accessories

	Designation	Description
	Immersion sensor max. pressure 25 bar L = 220 mm	Brass for $\varnothing 18$ sensor G $\frac{3}{4}$
		Brass for $\varnothing 18$ mm sensor $\frac{3}{4}$ - 14 NPT
		18/8 steel <sup>1)</sup> for $\varnothing 18$ sensor G $\frac{3}{4}$
	Immersion sensor max. pressure 25 bar L = 182 mm	Brass for $\varnothing 9.5$ sensor G $\frac{1}{2}$
		18/8 steel <sup>1)</sup> for $\varnothing 9.5$ sensor G $\frac{1}{2}$
	Mounting bracket	For AVTA
	Heat-conductive compound	5 gram tube 0.8 kg
	Nitrile diaphragm for mineral oil	For AVTA 10/15 For AVTA 20 For AVTA 25
	Capillary tube gland	G $\frac{1}{2}$ G $\frac{3}{4}$ $\frac{3}{4}$ - 14 NPT
	2 o-rings 2 diaphragms Valve cone	For AVTA 10/15 For AVTA 20 For AVTA 25

<sup>1)</sup> W1.4301

# General data on thermostatically operated cooling water valves

## Type AVTA

### Sizing

When sizing and selecting thermostatic valves, it is most important to ensure that the valve is able to give the necessary quantity of cooling water at any time, irrespective of the load. Therefore, to select a suitable size of valve it is necessary to know the precise amount of cooling required. On the other hand, to avoid the risk of unstable regulation (hunting), the valve should not be oversized. The type of charge must be selected on the basis of the temperature to be maintained, and on an assessment of the characteristics of each type, as described in the foregoing.

In general the aim should be to select the smallest valve capable of giving the required flow.

It is also recommended that the temperature range be chosen so that the required sensor temperature lies in the middle of the regulation range.

To help fine-setting the valve, a thermometer should be installed near the sensor.

### Valve size

The following data are used when selecting valve size:

- Required cooling water flow,  $Q$  [m<sup>3</sup>/h]
- Temperature rise in cooling water,  $[\Delta t]$  (°C)
- Differential pressure across valve,  $[\Delta p]$  (bar).

With fully open valve the differential pressure should be around 50% of the total pressure drop across the cooling system.

The diagrams on page 10 are intended to make valve sizing easier.

Fig. 1 - Relation between heat quantity [kW] and cooling water quantity

Fig. 2 - Graphs of  $k_v$  values

Fig. 3 - Valve operating range

Fig. 4 - Flow quantities as a function of pressure drop  $[\Delta p]$

### Example

A cooling water valve must be selected for the temperature regulation of a vacuum pump.

Since direct regulation of the oil temperature is required, an AVTA valve is suitable. The sensor position is horizontal - and small dimensions are desired.

Given data:

- Necessary cooling at full load 10 kW.
- Oil temperature to be maintained constant at +45°C
- Cooling water  $p_1 = 3$  bar
- Outlet  $p_3 = 0$  bar
- Cooling water temperature  $t_1 = +20^\circ\text{C}$
- Outlet temperature  $t_2 = +30^\circ\text{C}$

1. The graphs in fig. 1 can be used to find the necessary cooling water quantity at  $\Delta t = 10^\circ\text{C}$  (+30°C - +20°C) to 0.85 m<sup>3</sup>/h.

2. The graphs in fig. 2 show the necessary  $k_v$  value for 0.85 m<sup>3</sup>/h with

$$\Delta p = 1.5 \text{ bar} \quad \text{for } 0.7 \text{ m}^3/\text{h}.$$

3. The columns in fig. 3 show that all four AVTA valves can be used, but in practice an AVTA 10 or 15 should be selected.

The above considerations apply to both AVTA and FJVA valve types.

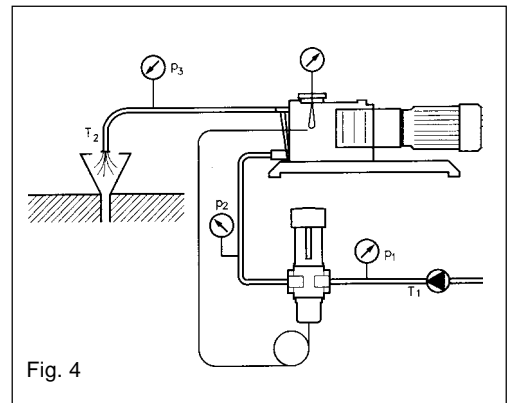

Fig. 4

Operating conditions and other product requirements in this example mean that a valve with adsorption charge is the correct choice. The temperature range +10 → +80°C is in order.

The table at the top of page 4 shows AVTA 10, code no. 003N1144, or AVTA 15, code no. 003N0107. Both fulfil the requirements named.

In many applications, installation conditions make the use of sensor pockets advisable.

“Accessories” on page 8 gives the code nos. for sensor pockets for  $\varnothing 9.5$  mm sensors in brass and stainless steel: 993N3569 and 003N0196, respectively.

# General data on thermostatically operated cooling water valves Type AVTA

## Sizing

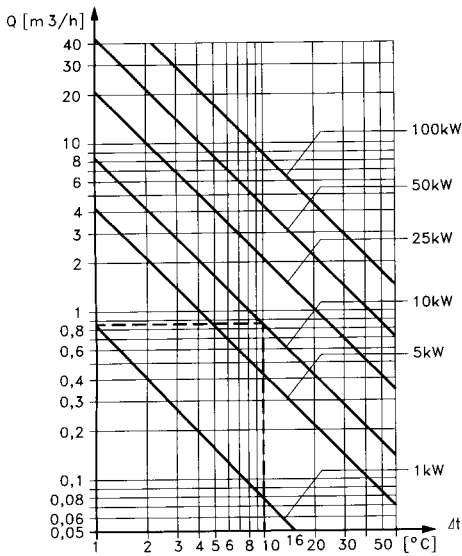

Fig. 1 Heating or cooling with water.  
Example: Necessary cooling output 10 kW, with  $\Delta t = 10^{\circ}C$ .  
Required flow 0.85  $m^3/h$ .

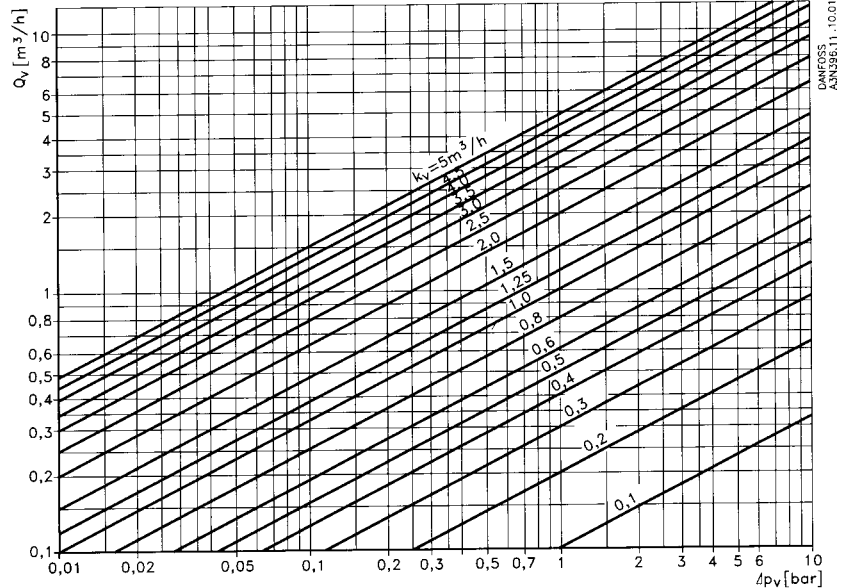

Fig. 2 Relation between water quantity and pressure drop across valve.  
Example: Flow 0.85  $m^3/h$  with a pressure drop of 1.5 bar.  
The  $k_v$  value becomes 0.7  $m^3/h$ .

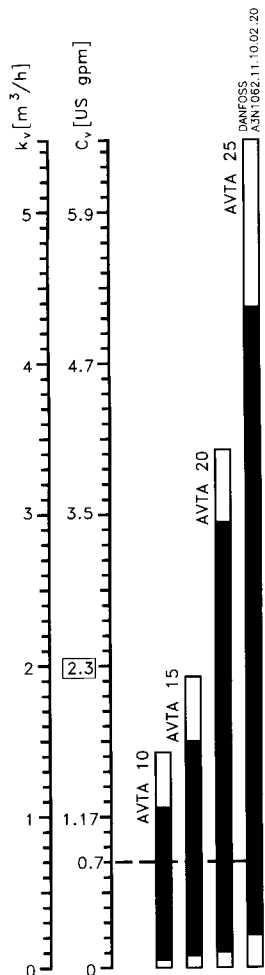

Fig. 3 Nomogram showing the valve  $k_v$  ranges.  $k_v$  values are always given for the water flow in  $m^3/h$  with a pressure drop  $D_p$  of 1 bar. The valve should be selected so that the necessary  $k_v$  value lies in the middle of the regulation range.  
Example: AVTA 10 and 15 are the most suitable for a  $k_v$  value of 0.7.

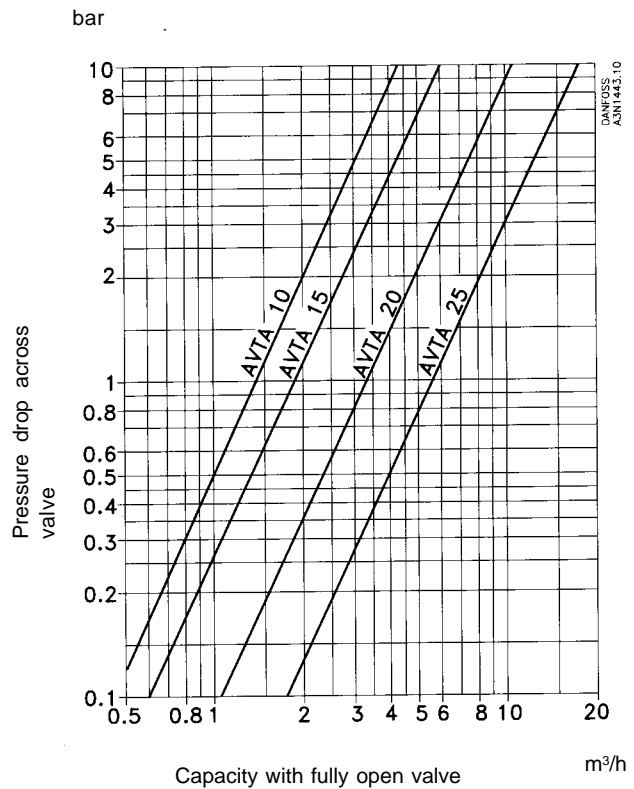

Fig. 4 Valve flow quantity in fully open position, as a function of pressure drop  $D_p$ .

# A COMPLETE PRODUCT RANGE



**ACCUMULATORS**



**WATER OIL COOLERS**



**LOW PRESSURE PUMPS**



**AIR OIL COOLERS**



**OIL FILTERS**



**ACCESSORIES**



# THE OLAER-GROUP AROUND THE WORLD

## AUSTRALIA

Olaer Fawcett Christie Hydr. Pty Ltd  
13 Boola Place, Cromer  
N.S.W. 2099  
Tel: +61 2 9981 6888  
Fax: +61 2 9981 6144  
E-mail: sales@olaer.com.au

## AUSTRIA

Olaer Speicher-Technik GmbH  
Haiderstraße 38  
AT-4052 Ansfelden  
Tel: +43 7229 80306  
Fax: +43 7229 80306-21  
E-mail: info@olaer.at  
www.olaer.at

## BELGIUM

S.A. Olaer Benelux N.V.  
Doornveld 4  
BE-1731 Zellik  
Tel: +32 2 466.15.15  
Fax: +32 2 466.16.24  
E-mail: info@olaerbe  
www.olaer.be

## CZECHIA

Olaer CZ s.r.o.  
Vidensk 125  
CZ-61900 BRNO  
Tel: +42 5 47125 601-3  
Fax: +42 5 47125 600

## CHINA

Fenghua Olaer Hydraulics Co. Ltd  
16 Xinfeng Road  
Fenghua City, Zhejiang  
Tel: +86 574 8922546/8911039  
Fax: +86 574 8911039

## DENMARK

Oiltech AB  
Møllebækvej 14  
DK-9632 MØLDRUP  
Tel: +45 86 69 20 38  
Fax: +45 86 69 23 38

## FINLAND

Oiltech Hydraulics OY  
Vattuniemenkatu 8, PI 190  
FI-00210 Helsinki  
Tel: +358 9 682 0422  
Fax: +358 9 682 2376  
E-mail: stig.soderstrom@oiltech-hydraulics.fi

## FRANCE

Olaer Industries S.A.  
16, rue de Seine, B.P. 7  
FR-92704 Colombes Cedex  
Tel: +33 1 41 19 17 00  
Fax: +33 1 41 19 17 20  
E-mail: olaer@olaer.com  
www.olaer.com

## GERMANY

Olaer Industries GmbH  
Zum Gunterstal 4  
DE-66440 Blieskastel  
Tel: +49 6842 9204-0  
Fax: +49 6842 9204-15  
E-mail: info@olaer.de

## HOLLAND

Olaer Nederland B.V.  
De Lind 10, Postbus 75  
NL-4840 AB Prinsenbeek  
Tel: +31 76-5412453  
Fax: +31 76-5411502  
E-mail: info@olaer.nl  
www.olaer.nl

## INDIA

Fawcett Christie Hydraulics India Pvt. Ltd.  
C-30, Shankara Park  
Shankarapuram  
Bangalore 560 004  
Tel: +91 806 60321  
Fax: +91 806 611716

## ITALY

Olaer Italiana S.p.A.  
Strada Fantasia 83  
IT-10040 Leini (TO)  
Tel: +39 011 991.85.11  
Fax: +39 011 997.80.97  
E-mail: olacomm@olaer.it  
www.olaer.it

## KOREA

Hyundai Olaer Hydraulic Co., Ltd.  
2NA-702 Shiwha Industrial Group  
Jungwang Dong  
Shihungsi, Kyunggido 429-450  
Tel: +82 345 499 0797-8  
Fax: +82 345 499 2249

## NORWAY

Oiltech AS  
Dynamitveien 23, PB 133  
NO-1401 Ski  
Tel: +47 64 87 42 65  
Fax: +47 64 87 43 21  
E-mail: oiltech@oiltech.no  
www.oiltech.no

## POLAND

Oiltech Polska  
ul. Grochowska 168  
PL-04357 WARSZAWA  
Tel: +48 22 612 04 73  
Fax: +48 22 610 74 82

## SOUTH AFRICA

Fawcett Christie Hydraulics  
c/o Rolton Products CC  
P.O. Box 43244  
ZA-Industria 2042  
Tel: +27 11 474 3095  
Fax: +27 11 474 8384

## SPAIN

Olaer-Oiltech Iberica, S.A.  
Travesia Industrial, no 29  
ES-08907 L'Hospitalet de LL.  
(Barcelona)  
Tel: +34 933 361 412  
Fax: +34 933 357 186  
E-mail: olaer@olaer.es  
www.olaer.es

## SWEDEN

Oiltech AB  
Förrådsvägen 2  
SE-181 41 Lidingö  
Tel: +46 8 636 07 00  
Fax: +46 8 767 97 56  
E-mail: info@oiltech.se  
www.oiltech.se

## SWITZERLAND

Olaer (Schweiz) AG  
Bonnstraße 3  
CH-3186 Düringen  
Tel: +41 26 492 70 00  
Fax: +41 26 492 70 70  
E-mail: info@olaer.ch  
www.olaer.ch

## UNITED KINGDOM

Fawcett Christie Hydraulics Ltd.  
Sandycroft Industrial Estate  
Chester Rd, Sandycroft  
Deeside, Flintshire CH5 2QP  
North Wales  
Tel: +44 1244 535515  
Fax: +44 1244 533002  
E-mail: sales@fch.co.uk  
www.fch.co.uk

## USA

Oil Air Hydraulics Inc.  
11505 West Little York  
Houston, Texas 77041  
Tel: +1 713 937 89 00  
Fax: +1 713 937 04 38  
E-mail: oilair1@pdq.net  
www.fluidpower.com

Please note: Being a renowned manufacturer of cooling systems for hydraulics, Oiltech is constantly seeking ways to improve the specification and design of its products and alterations take place continually. The products in this brochure may be updated, altered in any way or discontinued, without prior notice.